

STANDARD CAPACITANCE TVS ARRAY

APPLICATIONS

- ✓ Ethernet - 10 Base T
- ✓ Cellular Phones
- ✓ Handheld Electronics
- ✓ FireWire & USB Interfaces

IEC COMPATIBILITY (EN61000-4)

- ✓ 61000-4-2 (ESD): Air - 15kV, Contact - 8kV
- ✓ 61000-4-4 (EFT): 40A - 5/50ns
- ✓ 61000-4-5 (Surge): 12A, 8/20 μ s - Level 1(Line-Gnd) & Level 2(Line-Line)

FEATURES

- ✓ 350 Watts Peak Pulse Power per Line (tp=8/20 μ s)
- ✓ Monolithic Design
- ✓ Protects 4 Lines
- ✓ ESD Protection > 25 kilovolts
- ✓ Low Clamping Voltage
- ✓ Unidirectional Configuration
- ✓ Low Leakage Current
- ✓ RoHS Compliant

MECHANICAL CHARACTERISTICS

- ✓ Molded JEDEC SOT-23-6 Package
- ✓ Weight 16 milligrams (Approximate)
- ✓ Available in Lead-Free Pure-Tin Plating(Annealed)
- ✓ Solder Reflow Temperature:
Pure-Tin - Sn, 100: 260-270°C
- ✓ Flammability Rating UL 94V-0
- ✓ 8mm Tape and Reel Per EIA Standard 481
- ✓ Marking: Marking Code & Pin One Defined By DOT on Package



PIN CONFIGURATION

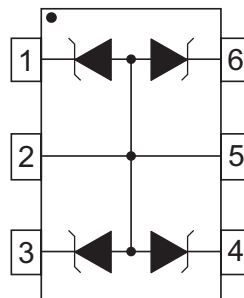

DEVICE CHARACTERISTICS

MAXIMUM RATINGS @ 25°C Unless Otherwise Specified

PARAMETER	SYMBOL	VALUE	UNITS
Peak Pulse Power ($t_p = 8/20\mu s$) - See Figure 1	P_{PP}	350	Watts
Operating Temperature	T_L	-55 to 150	°C
Storage Temperature	T_{STG}	-55 to 150	°C

ELECTRICAL CHARACTERISTICS PER LINE @ 25°C Unless Otherwise Specified

PART NUMBER (See Notes 1)	DEVICE MARKING	RATED STAND-OFF VOLTAGE V_{WM} VOLTS	MINIMUM BREAKDOWN VOLTAGE @ 1mA $V_{(BR)}$ VOLTS	MAXIMUM CLAMPING VOLTAGE (See Fig. 2) @ $I_p = 1A$ V_C VOLTS	MAXIMUM CLAMPING VOLTAGE (See Fig. 2) @ 8/20 μs $V_C @ I_{PP}$	MAXIMUM LEAKAGE CURRENT @ V_{WM} I_b μA	TYPICAL CAPACITANCE (See Note 2) 0V @ 1 MHz C_j pF
PD10927	PRH	5.0	6.0	9.8	21.0V @ 17.0A	20	150

Note 1: Test between pin 1 to 2 or 5, 4 to 2 or 5, 6 to 2 or 5, 3 to 2 or 5.

Note 2: Capacitance measured between pins 1, 3, 4, 6, to 2.

FIGURE 1
PEAK PULSE POWER VS PULSE TIME

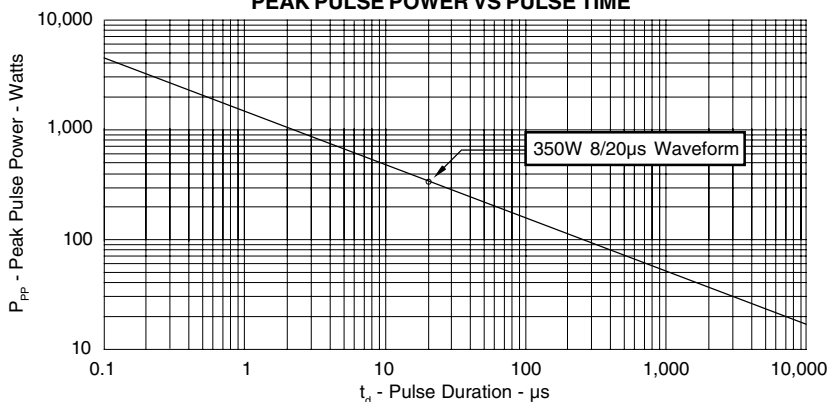
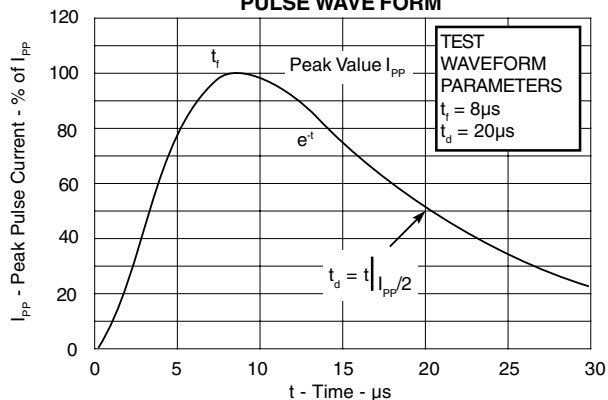
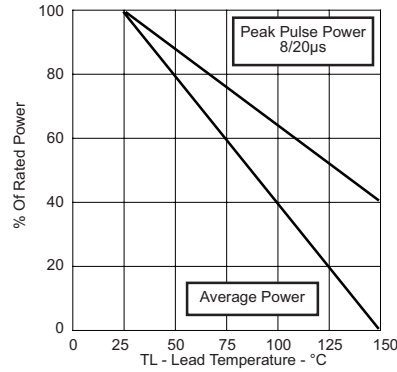

FIGURE 2
PULSE WAVEFORM



GRAPHS

**FIGURE 3
POWER DERATING CURVE**



**FIGURE 5
TYPICAL REVERSE VOLTAGE VS CAPACITANCE**

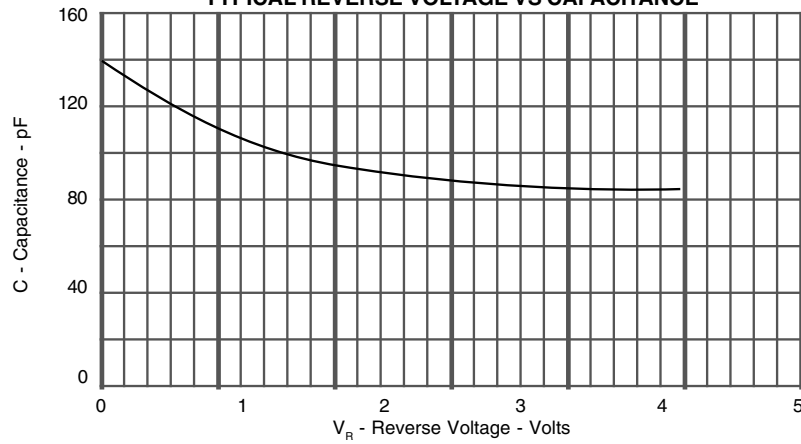

APPLICATION NOTE

The PD10927 is a TVS array designed to protect I/O or data lines from the damaging effects of ESD or EFT. This product provides unidirectional and protection, with a surge capability of 350 Watts P_{PP} per line for an 8/20 μ s waveform and ESD protection > 25 kilovolts.

UNIDIRECTIONAL COMMON-MODE CONFIGURATION (Figure 1)

The device provides up to four (4) lines of protection in a common-mode configuration as depicted in Figure 1.

Circuit connectivity is as follows:

- ✓ Line 1 is connected to Pin 1.
- ✓ Line 2 is connected to Pin 3.
- ✓ Line 3 is connected to Pin 4.
- ✓ Line 4 is connected to Pin 6.
- ✓ Pin 5 is connected to ground.
- ✓ Pin 2 is not connected.

Figure 1 - Unidirectional Configuration
Common-Mode I/O Port Protection

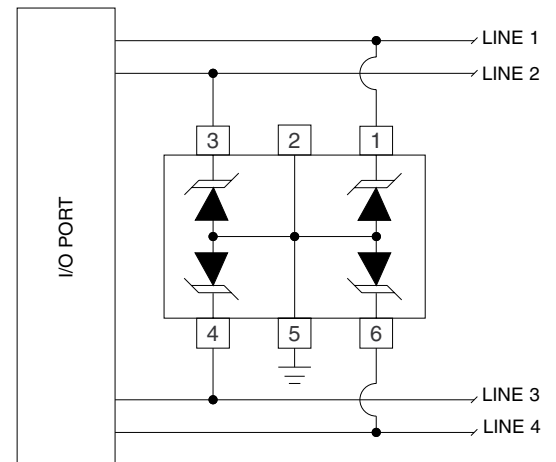

CIRCUIT BOARD LAYOUT RECOMMENDATIONS

Circuit board layout is critical for Electromagnetic Compatibility (EMC) protection. The following guidelines are recommended:

- ✓ The protection device should be placed near the input terminals or connectors, the device will divert the transient current immediately before it can be coupled into the nearby traces.
- ✓ The path length between the TVS device and the protected line should be minimized.
- ✓ All conductive loops including power and ground loops should be minimized.
- ✓ The transient current return path to ground should be kept as short as possible to reduce parasitic inductance.
- ✓ Ground planes should be used whenever possible. For multilayer PCBs, use ground vias.

SOT-23-6 PACKAGE OUTLINE & DIMENSIONS

PACKAGE OUTLINE

SOT-23-6

PACKAGE DIMENSIONS

DIM	MILLIMETERS		INCHES	
	MIN	MAX	MIN	MAX
A	2.80	3.05	0.110	0.120
B	1.50	1.75	0.059	0.070
C	0.90	1.30	0.036	0.051
D	0.30	0.40	0.012	0.016
E	0.85	1.05	0.033	0.040
G	0.90	1.45	0.036	0.057
J	0.09	0.20	0.003	0.008
K	2.60	3.00	0.102	0.118
L	0.0	0.15	0.0	0.006
M	0.30	0.60	0.012	0.024

MOUNTING PAD

TYPICAL		
DIM	Millimeters	Inches
1	0.70	0.028
2	1.90	0.074
3	0.95	0.037
4	2.40	0.094
5	1.00	0.039

NOTES

1. Dimensioning and tolerances per ANSI Y14.5M, 1985.
2. Controlling Dimension: Inches
3. Dimensions are exclusive of mold flash and metal burrs.

TAPE & REEL/BULK ORDERING NOMENCLATURE

1. Surface mount product is taped and reeled in accordance with EIA-481.
2. Suffix -T7 = 7 Inch Reel - 3,000 pieces per 8mm tape, i.e., PD10927-T7.

Outline & Dimensions: Rev 3 - 3/08, 06013

Tape & Reel Specifications (Dimensions in millimeters)

Reel Dia.	Tape Width	A0	B0	K0	D	E	F	W	P0	P2	P	tmax
178mm (7")	8mm	3.20 ± 0.10	3.20 ± 0.10	1.65 ± 0.10	1.50 ± 0.10	1.75 ± 0.10	3.50 ± 0.05	8.00 ± 0.30	4.00 ± 0.10	2.00 ± 0.05	4.00 ± 0.10	0.25

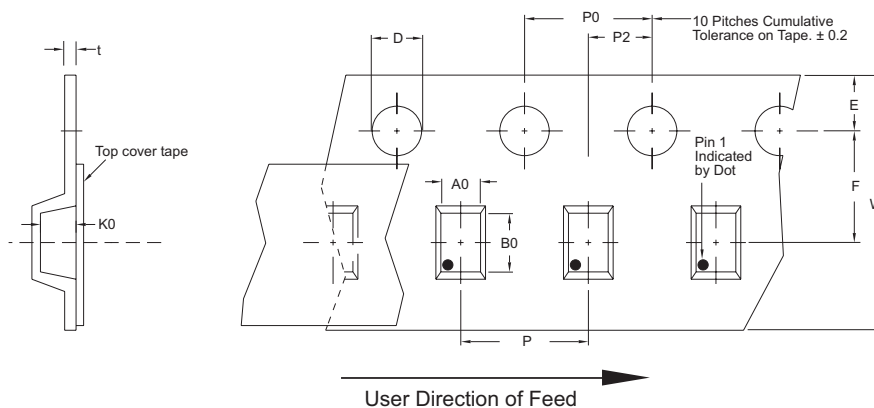

COPYRIGHT © ProTek Devices 2007

SPECIFICATIONS: ProTek reserves the right to change the electrical and or mechanical characteristics described herein without notice (except JEDEC).

DESIGN CHANGES: ProTek reserves the right to discontinue product lines without notice, and that the final judgement concerning selection and specifications is the buyer's and that in furnishing engineering and technical assistance, ProTek assumes no responsibility with respect to the selection or specifications of such products.

ProTek Devices
 2929 South Fair Lane, Tempe, AZ 85282
 Tel: 602-431-8101 Fax: 602-431-2288
 E-Mail: sales@protekdevices.com
 Web Site: www.protekdevices.com